

# Hi-Velocity Systems

Explained, Inside and Out

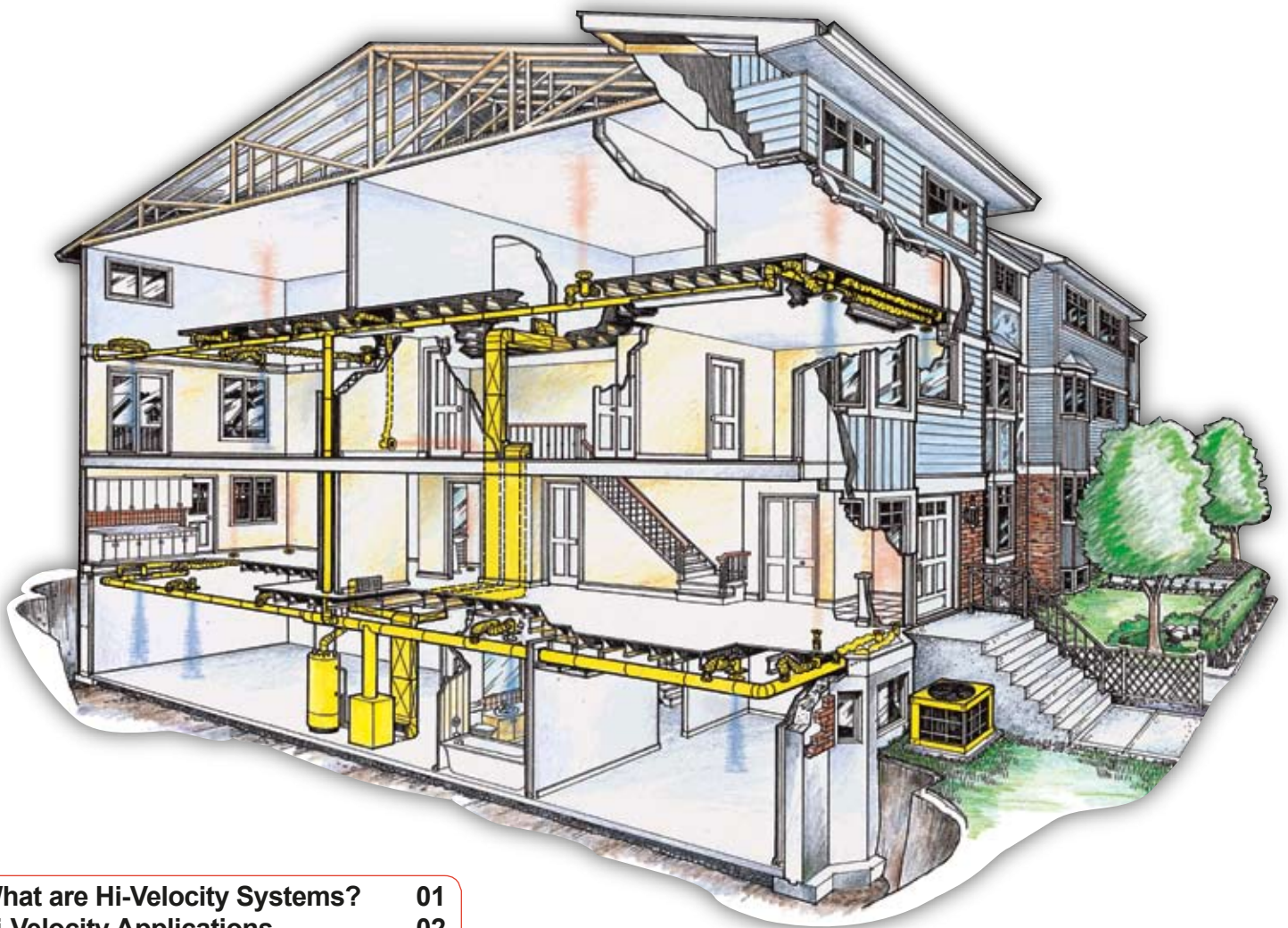

What are Hi-Velocity Systems?	01
Hi-Velocity Applications	02
Science of Hi-Velocity Systems	03
How Hi-Velocity Cooling Works	04
Printed Circuit Board	05
Controls and Operation	07
Hi-Velocity Tools	08

[www.hi-velocity.com](http://www.hi-velocity.com)

**Single side access  
for easy service  
and installation**

**Return air connection  
to the back, bottom or  
either side**

Round 8" or 10"  
Plenum Makes for  
Fast Installations

Powder Coated Cabinet  
Provides an Attractive  
and Durable Finish

Slide in Heating  
Coil

Slide in Blower

Four Row Coil  
Optimizes  
Heat Transfer

Multi-Speed Motor

Acoustic Insulation  
Minimizes Noise  
Transfer

24 Volt Transformer

Printed Circuit Board  
Minimizes Field Wiring  
and is Heat/Cool Ready

Variable Speed Controls  
for both Continuous  
Fan and Heating

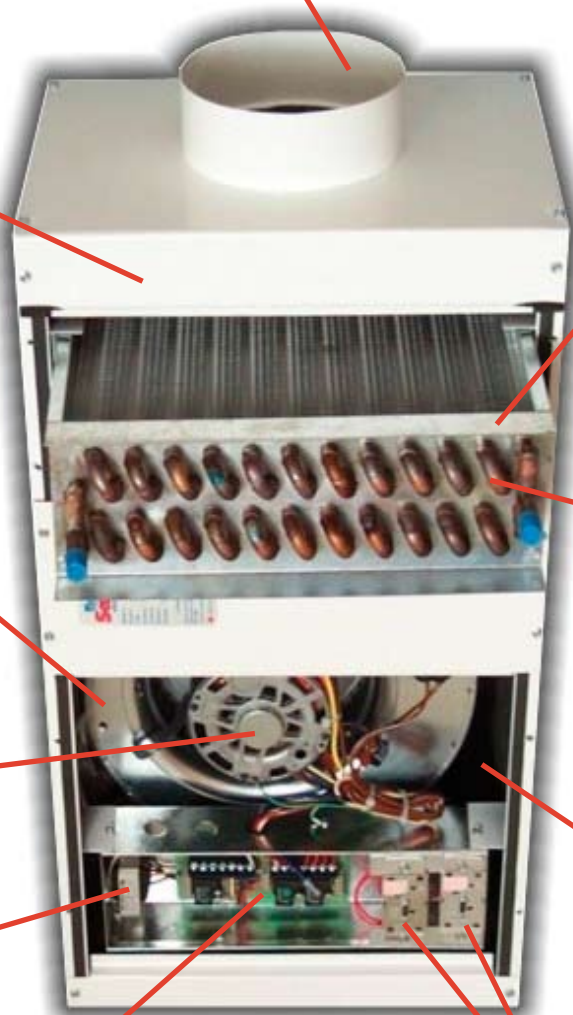

# What are Hi-Velocity Systems?

The Hi-Velocity System is a high pressure forced air delivery system that can be designed to provide heating, cooling, filtration, ventilation, and humidification. The Hi-Velocity System has been pre-engineered and works on the principle of pressure rather than air velocity.

The Hi-Velocity System does not make or break any existing laws; it just uses those laws differently than a conventional low velocity system. It is quite different from a conventional furnace, the main difference being that the supply duct work is all “small diameter” or “mini duct”.

Because the plenum duct is pressurized, dust build-up within the duct work is eliminated. With continuous air circulation from the constant fan, airborne dust and other allergens can be easily filtered out of the air. With a pressurized small diameter duct we condition the air differently than conventional forced air systems. With the use of a high pressure area to low pressure area, we continuously mix the room air, creating even temperatures from floor to ceiling.

Our Cooling modules are highly efficient and very effective at removing moisture from the air. Not only do we cool the air, we use a lower air velocity which allows the Hi-Velocity System to remove more moisture from the passing air molecules.

The Hi-Velocity System achieves a superior Indoor Air Quality (IAQ) with an innovative fan coil and cooling module design. This technology helps create a healthier and more enjoyable indoor living environment for the end-user.

## The key to Hi-Velocity Systems - How we Provide these Benefits:

- Our fan coil units are modular, conveniently located, and can be installed in a variety of orientations.
- Round plenum duct for easy installation
- Our 2” flex duct delivers air under a greater pressure than a conventional system. This increase in pressure forces the mixing of the air in the room, eliminating stratification.
- Our 2” flex duct is insulated to prevent heat loss/gain and has a sound absorbing inner core to deliver the air whisper quiet.
- Smaller duct also allows for greater flexibility in installations while saving space.
- Vents are adjustable and can be installed in the floor, ceiling or wall in a variety of styles to blend in with their surroundings.

# IAQ

## Hi-Velocity Systems Improve Indoor Air Quality

In the last several years, scientific evidence has indicated that the air within homes and other buildings can contain more pollutants than the outdoor air. With people spending approximately 90 percent of their time indoors, the health risks may be greater to exposure of air pollution indoors than outdoors. People who may be exposed to indoor air pollutants for the longest periods of time are often those most susceptible to the effects. Such groups include the young, elderly, chronically ill, or people suffering from respiratory or cardiovascular disease.

Hi-Velocity Systems can provide the answers to all your Indoor Air Quality needs. The Hi-Velocity System utilizes a constant fan for air delivery which can help eliminate conditions that promote mold and mildew. By controlling your environment with continuous air circulation and moisture control, conditions that will allow these harmful spores the opportunity to take hold are reduced.

For people dealing with respiratory or cardiovascular disease, the Hi-Velocity System can easily be used in conjunction with add on filtration equipment. With the versatility of our units, charcoal, electronic, electrostatic, and hepa filters are easily added on to provide you with a cleaner and healthier living environment. When dealing with moisture, humidifiers, de-humidifiers, and atomizers can all be used in conjunction with the Hi-Velocity System. Fresh air can be supplied directly, or indirectly through the use of a heat exchanger.

## How the Hi-Velocity System can - Improve your Indoor Air Quality:

- Even temperature throughout the structure
- Filtration
- Fresh air make-up
- Humidification
- Dehumidification
- Reduce conditions that promote mold and mildew

**Hi-Velocity**  
Systems

# Applications for Hi-Velocity Systems



**Commercial**



**Multi-Family**



**New Construction**



**Retrofits**

The Hi-Velocity System can be utilized for most projects, but some typical installations are commercial, multi-family, new housing construction and the retrofit market. With the versatility, quick installation and superior Indoor Air Quality provided from our systems, they are now a popular choice with home builders, installers and the end user.

## Commercial

In commercial applications, exposed plenum with drilled outlets is the ideal choice. Drilled outlets are commonly used to supply a large area with heating and cooling. They can also create a pressurized air curtain for bay doors or large openings to the outside environment.

## Multi-Family

Many building contractors are utilizing our specially designed HV-52 units for multi-family structures. The Space Saver model is the same as other Hi-Velocity Systems with the exception of the supply air take-off. It was designed for closer take-off points. This model comes with 5 available supply outlet locations, four 6" supply outlets and one 8" outlet. With the adaptability of this unit, it will fit in almost any closet, crawlspace, or anywhere else where space is an issue.

## New Construction

When you want to improve your living standards, the Hi-Velocity System is the right choice for cooling and heating. Why waste space framing out large duct runs reducing the your livable area when small round plenum and flexible ducts can be run through floors, walls and ceilings. Not only will you improve your living standards with the Hi-Velocity Systems, they save you space allowing you to enjoy your home that much more.

## Retrofit

In older homes upgrading the heating and cooling system, there is no better choice than the Hi-Velocity System. The small ducts are easy to pull through walls, floors and ceilings with very little changes to the existing structure.

## Features of the Hi-Velocity System

- Unit Pre-assembled from the manufacturer.
- Flexibility in unit location; can be mounted Vertical, Horizontal or in the Counter Flow position.
- Printed Circuit Board Pre-Wired for Heating and Cooling.
- Cooling and Heating modules can easily be added to any unit at the time of purchase, or later as an upgrade.
- Large selection of Heating and Cooling modules:
  - Water Cooling modules (WCM)
  - Refrigerant Cooling Modules (RCM)
  - Water Heating Coils (HCA)
  - Electric Strip Heating Coils (ESH)
- Heat Pump compatible.
- 8" and 10" Round Plenum makes installation easier and increases usable space.
- Our pre-assembled flexible 2" duct is available in 10' and 15' standard lengths.
- Flexible 2" duct Extension kits for longer runs.
- Vents can be adjusted for fine tuning.
- Variety of vent plates to match any decor.
- Variable Speed Controls.
- Single Side Access for easy maintenance.
- Adjustable TX valve.
- Can be used with R-22 / R-407c / R-410a.
- Positive Flow Drain Pan eliminates standing water in the coil.
- Easily adaptable for humidifiers and HRV's.

# The Science and History of Hi-Velocity Systems

Calvin Dodd MacCracken (1920-1999), an engineer and inventor from New Jersey, is credited with building the first “high velocity” style air handler, using small insulated ducts to deliver heated air at considerable pressure and high velocity. This system quickly gained in popularity, and as public interest grew, a company called Space Conditioning Inc. incorporated the MacCracken Forced-Air House Heating Apparatus (Patent 2,488,548) into their product lines. This unit later became known as the “Jet-Heet” System. The primary market for the system was retrofit cooling into homes that had little room for duct work or in which architectural changes were undesirable. MacCracken’s air handler was based on two scientific principles:

**Bernoulli’s Principle:** (Daniel Bernoulli 1700-1782) Where there is decreased flow, you will find increased pressure. Where there is increased flow, you will find decreased pressure.

**Venturi Effect:** (Giovanni Battista Venturi 1746-1822) The increase in the velocity of a fluid stream as it passes through a constriction in a channel. Calculated by the Continuity Equation  $Q = VA$  where  $Q$  is the volumetric flow rate,  $A$  is the area of flow and  $V$  is the fluid velocity. Because  $Q$  does not change, as  $A$  gets smaller then  $V$  must increase.

## Bernoulli’s Principle

Bernoulli’s Principle plays an important part in the operation of the Hi-Velocity System. To illustrate how this works, let’s look at the dynamics of a showerhead. With the showerhead in place, you create pressure in the piping and move a small amount of water quickly through the showerhead holes, with the water being equally distributed to each hole. If you remove the showerhead, you remove the pressure, and begin moving a lot of water slowly and in one big stream. It takes the same amount of energy to move a small amount of water quickly, as it does to move a large amount of water slowly. The amount of energy you have available depends on your water pressure. The small holes in the showerhead create a pressure point in your water line, making the water moving through that pipe retain a high pressure and low velocity. Once the water leaves the showerhead, it is no longer under pressure, so the velocity increases.

This is very similar to how the airflow works with the Hi-Velocity System. Our fan coil pressurizes the duct work just like the water pipe of your shower. Our 2” vent outlets act like the holes in the showerhead to convert the pressure to velocity, and deliver the conditioned air to your home. Since airflow and water flow follow the same principles, you will get equal airflow from all of the Hi-Velocity System vents in your home. This holds true from the first branch duct to the last one, and is modified only due to friction from longer lengths of branch ducts.

The system maintains a high pressure within the duct which results in a low air flow within the duct work. When released from the duct, this pressure is converted to velocity at the outlet, going from a high pressure area to a low pressure area (the open room). The higher velocity of the air leaving the duct forces the air within the room to mix based on the Venturi Effect.

## Venturi Effect

When the higher-pressure air leaves the vent of the Hi-Velocity System, it expands rapidly and causes a lower air pressure around the vent. This causes the room air to be drawn toward the airstream that is leaving the vent. By applying the Venturi Effect, the Hi-Velocity System causes the thorough and continual mixing of room air, eliminating the possibility of hot and cold spots from developing in the home. With other air systems that operate with less pressure, this effect does not occur to any appreciable amount. With the Hi-Velocity System, whether the vents are located in the floor, ceiling or wall, complete and consistent mixing of the air will always occur. To allow for custom levels of comfort, every vent has a built-in damper, making it easy to control individual room temperatures.

## Vent Outlet Utilizing the Venturi Effect

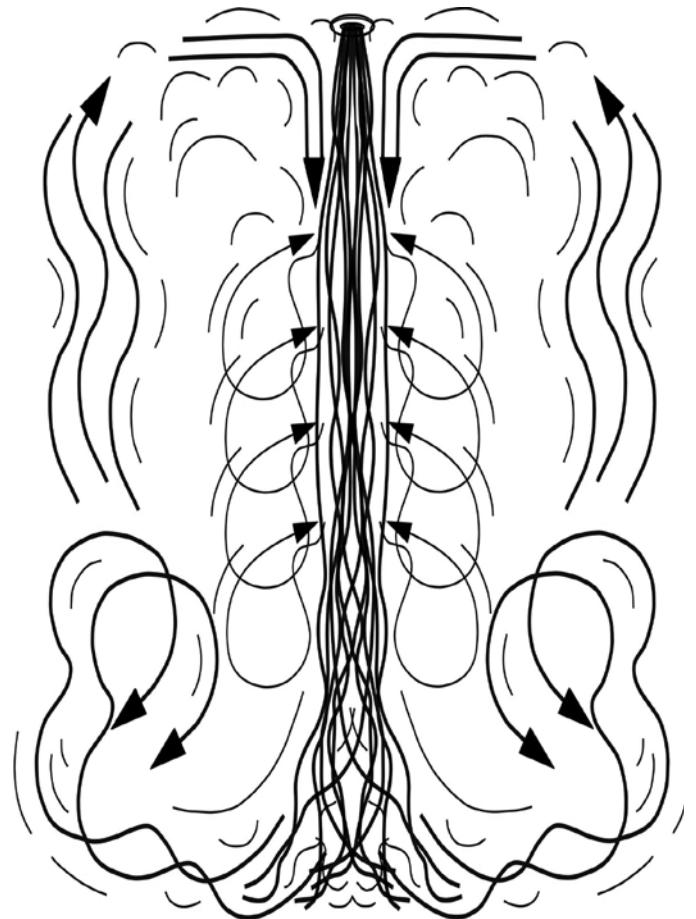

# How Hi-Velocity Cooling Works

With a conventional low velocity forced air-cooling system, the rule that everyone knows is a volume of 400 Cubic Feet of air per Minute (CFM) for each ton. With 400 CFM at a low static pressure, and a large face area / thin depth coil, the air is cooled and a small amount of humidity is removed. With the Hi-Velocity System, we use a lower CFM but higher static pressure to accomplish the same amount of cooling, removing more humidity from the air in the process.

400 CFM is a design rule for conventional heating systems and will put an optimum load on the indoor coil. This allows the coil to properly evaporate refrigerant and perform heat transfer. Since conventional heating systems use a lower pressure than Hi-Velocity Systems, a higher airflow is needed to provide enough mass of air to perform the heat transfer. Inversely, the more pressure that the air is under, the less CFM is needed. How this works is on the microscopic level; the amount of air molecules present through the coil determines how much heat transfer is done. Under a higher pressure there are more air molecules present per cubic foot. The Hi-Velocity System requires less CFM of air to pass through the evaporator, while still providing the same coil load.

With as much coil load (if not more) passing through the evaporator, equal or superior cooling will result. An additional benefit to moving more air molecules through the coil at a lower rate is the latent cooling. Since the air passing through the coil is in contact with the coil surface area for a longer period of time, the temperature is dropped lower than with conventional systems, thus reducing the air's ability to hold moisture. Our coils have a unique design; they are highly efficient and typically thicker than coils in conventional cooling systems. With our style of cooling coil we will remove up to thirty percent more moisture from the air. This has the benefit of allowing a greater thermal comfort level, even at a higher temperature.

Air velocity can be either a help or a hindrance to thermal comfort levels. While a small amount of air movement is desirable to increase the skin evaporation rate, it has to be a uniform movement over the entire body in order to provide benefits to thermal comfort levels. Any large amounts of direct air velocity over a part of the human body will cause an uneven rate of evaporation and heat transfer. This is why the vents for the Hi-Velocity System are usually located in low traffic areas such as corners of a room, or to the sides of doors and windows. By locating the vents in these areas, the amount of direct air movement that humans will come in contact with will be minimized, since the vents have only an eight-inch cone of direct influence.

Air temperature, humidity, and direct air velocity are the factors that will cause the most change to thermal comfort levels. Most people believe that cold air is the key factor for a good air conditioning system. Considering that the human body has a natural cooling system built in, the key to creating a comfortable environment for the human body is to create the right combination of environmental factors.

## Parameters that describe thermal comfort.

- Air temperature
- Wet-bulb temperature
- Dew point temperature
- Water vapor pressure
- Total atmospheric pressure
- Relative humidity
- Humidity ratio
- Air velocity
- Mean radiant temperature

Air temperature is only the starting point in creating a comfortable environment. By reducing the inside air temperature to 70°F a person may be comfortable to a certain degree. However, in a high humidity location, you could still have the clammy feeling due to all the moisture in the air. The body will naturally evaporate this moisture, which could lead to a cold uncomfortable feeling. When the humidity level is controlled at a proper level a person can be comfortable at a higher indoor temperature. With no evaporation on the skin surface being experienced, no heat transfer will be taking place, allowing the individual to enjoy a constant temperature on the skin surface.

Air velocity within a room can also have a big effect on comfort. When not enough airflow is introduced, stratification and room separation may occur. Stratification is the layering of hot and cold air; hot air will always rise and can result in a big temperature difference from floor to ceiling. In conventional systems which use the throw and diffusion method, separation can occur from one side of the room to the other, with the air closer to the vent usually being colder. Both stratification and separation happen when there is no means of circulating the room air. The Hi-Velocity System provides constant air circulation through the Venturi affect, never allowing stratification or room separation to occur.

# Printed Circuit Board

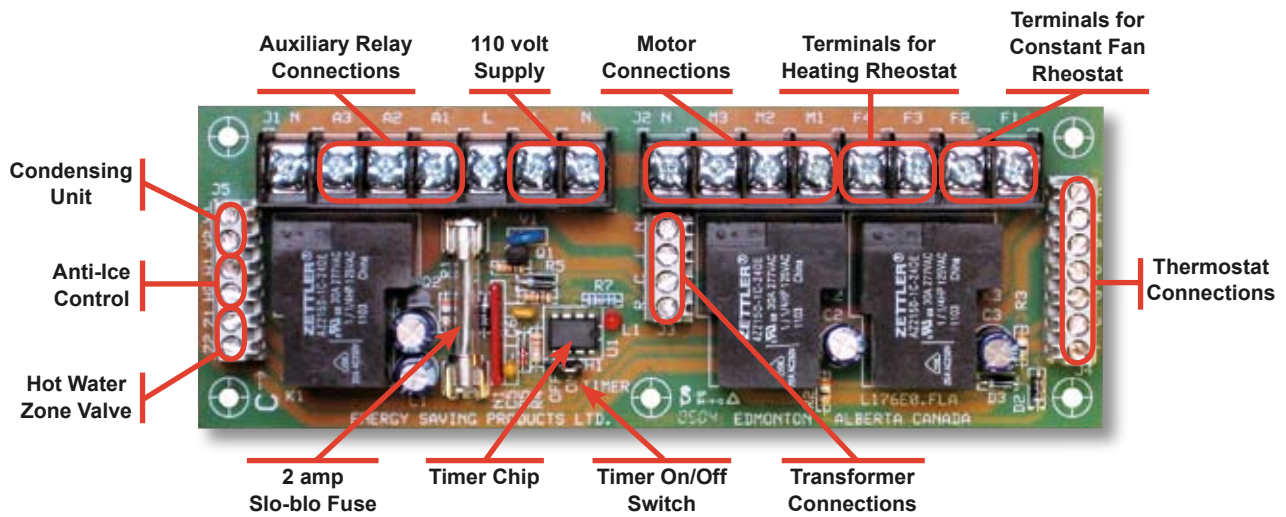

The Hi-Velocity Circuit board makes wiring of the unit a quick and simple task. With clearly labeled connections, it is easy to wire in the thermostat, condenser and anti-ice control. With our Auxiliary Relay and Dry Contact connections, any application that requires 24 volt, 110 volt, or dry contacts (boilers, hot water heaters, heat pumps, humidifiers) can be automatically started when there is a call for heat. When the Hi-Velocity System is used to supplement radiant floor heating, the Hot Water Zone Valve terminals automatically activate the zone valves.

When power is applied to the Printed Circuit Board without any call for heating or cooling, the low speed motor windings are energized. This will provide you with constant fan operation and can be controlled through the use of the Low Speed Rheostat. On a call for heat, the motor will switch to high speed and can be controlled with the High Speed Rheostat. If the constant fan operation is not wanted, you can shut it off by turning the low speed rheostat counter clockwise until it clicks into the off position.

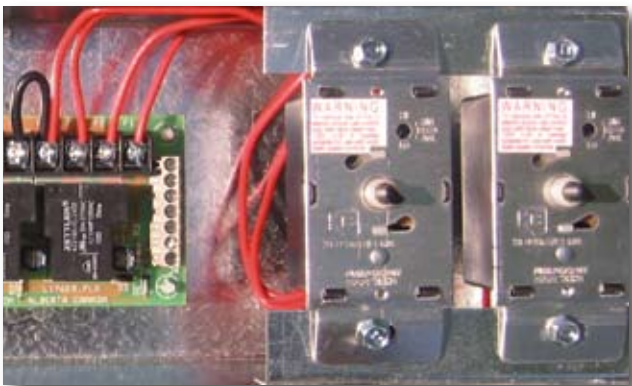

**Variable Speed Rheostats**

## Timer Chip

The printed circuit board within the fan coil contains a timer circuit. On some systems (when applicable), this timer will cycle the pump on potable water systems, to flush the water through the system during summer months and prevent any stagnation. The timer circuit is equipped with a red flashing light in the center of the circuit board. It is normal for the red light to be flashing as it is showing us that power is being supplied to the unit.

## Circuit Board Features:

- Fan coil unit is ready for both heating and cooling with no additional relays required.
- 24v transformer is factory installed and wired.
- Auxiliary heating relay is included for either 110v, 24v, or dry contact applications.
- Factory installed speed controls for both constant fan and heating operation.
- R W G Y terminals for thermostat hookup follow industry standards for ease of installation.
- Terminals for your heating zone valve, cooling condensing unit, and anti-ice control are supplied to simplify the field control wiring.
- Dynamic pump duty cycle chip provided to prevent water stagnation in potable water systems and to provide pump rotor protection.
- Slow-blow fuse provided for circuit board protection.

# Hi-Velocity Control Panel

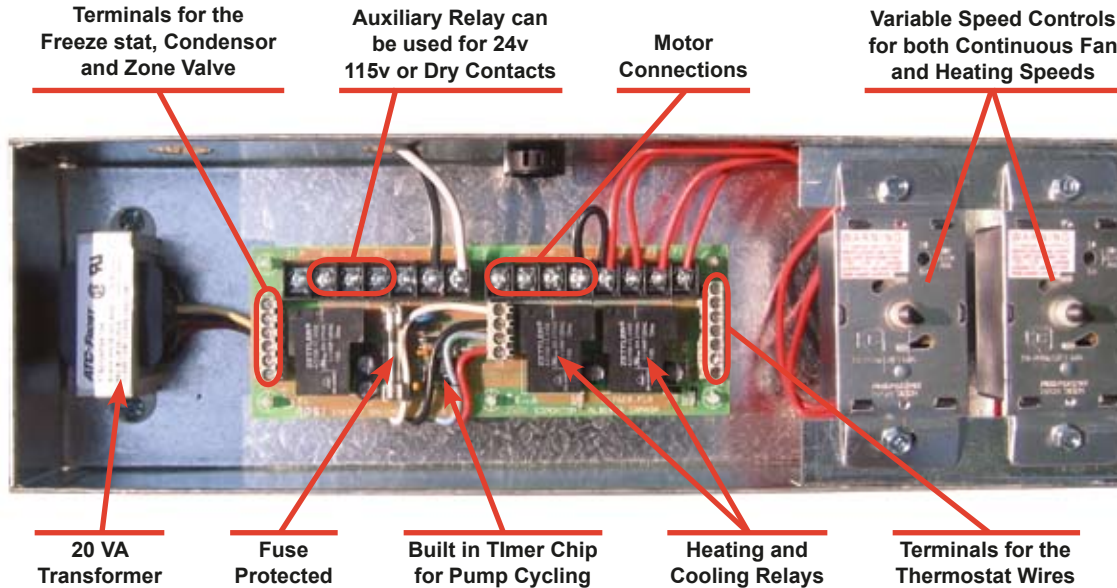

## Heating Mode

Boilers, hot water tanks, heat pumps, and geothermal systems can all be used as heat sources for the Hi-Velocity System. We also manufacture a slide-in electric strip coil that is available for use with the system, easily installed without any external mounting or duct work required.

When the unit is in heating mode, the Auxiliary relay is also engaged. The most common use for this relay is to start a circulator pump for heating; however, the auxiliary relay can be used for 110 volt, 24 volt, or dry contact operation depending upon your needs. Also in heating mode, 24 volt power is supplied to the Zone Valve Terminals in case you have a normally closed zone valve with your fan coil. With more people using radiant floor heating, our circuit board reduces the use of third party relays resulting in a faster installation and helping the installer to diagnose any problems in the future.

The circulator timer chip on our circuit board will energize the pump for 5 minutes every 24 hours. This timing cycle starts when power is turned on to the fan coil unit, and will be engaged at the same time every day. If you wish to have the timer cycle operate at a specific time of day, simply turn off power to the fan coil unit for three seconds at that time of day, then turn the power back on. If you do not need to use the timer circuit, the jumper header can be changed from the ON position to the OFF position and it will be disabled.

## Cooling Mode

Condensing units, chillers, heat pumps and geothermal systems can all be used as cooling sources for the Hi-Velocity System.

When the fan coil goes into cooling mode, the motor switches to high speed and will bypass the high speed rheostat. Proper airflow is very important when the unit is cooling, and our printed circuit board ensures the motor

speed is always correct. In cooling mode, 24 volt power is supplied to the Condenser Unit terminals which starts the outdoor condenser. This power first passes through the Freeze Stat terminals, ensuring the unit is in a ready state.

## Potable Water Timers

In recognition of concerns expressed by Plumbing Inspection Departments, Engineers, Home Builders, Home Owners, and Installing Contractors, the Hi-Velocity System offers a timer processor which can be enabled on our printed circuit board. This allows water from an approved dual purpose water heater to be circulated for a five minute period every 24 hours.

The timer processor overcomes the possible concern of water contamination within the system. It also has the added benefit of duty cycling the circulator every day, eliminating a locked rotor which is sometimes experienced during long shut down periods on water lubricated circulators. The time operation can be set at any time by disconnecting the 110 volt power source to the fan coil, and then re-connecting. Each time power is applied to the unit, the timer activates the five minute override, confirming operation.

Even on closed loop boiler systems, the timer processor can be beneficial. In a closed loop system, water contamination is not a concern, but duty cycling the zoning controls will increase the life expectancy of those controls. In addition to helping to reduce locked rotors on circulators, the processor will also duty cycle hydronic zone valves. Approximately 80% of all zone valve failure can be directly related to stuck ports due to off season build up. The timer processor was developed from consumer input and can greatly increase system reliability.

# Hi-Velocity Systems Controls and Operation

## System Operation

On the Hi-Velocity System, the fan coil unit has a two speed fan/motor assembly. On the main access door there may be one or two control dials, one which is labeled Constant Fan Control, and the other which is labeled Heating Fan Control.



## Constant Fan Control

The Constant Fan Control is enabled when there is no demand for heating or cooling from the thermostat. This control will enable you to adjust the fan speed to your own comfort level. It is optional and can be turned off if not desired.

There is great benefit with using this constant fan control. It provides filtration continually, and can also help reduce your energy costs for your home by gently “stirring” the air within your home constantly. This can eliminate hot and cold spots (stratified air) that can commonly occur with conventional systems, and can save you energy as it prevents the majority of the heat accumulating at the ceiling, creating a more even temperature throughout the home.

## Heating Fan Control

In the case of heating, the Heating Fan Control enables the fan speed to be adjusted on a demand for heat from the thermostat (not applicable to heat pumps). In most cases, it is recommended to keep this control on the high setting. This can easily be adjusted if longer heat cycles are desired, or if you wish to tone down the airflow from the system.

## Cooling Automatically Controlled

When the Hi-Velocity System switches to Cooling mode, the motor is automatically set to high speed, to ensure proper airflow across the coil. This will result in the best possible cooling and moisture removal from the system.

## System Efficiency/Performance

The constant fan reduces the amount of stratification within the home, and even with the heating/cooling off it can give you much more even temperatures between floors. This feature basically gives you a constant “stirring” effect of the air throughout the house. The amount of power actually used with this constant fan operation is about the same as a 100w light bulb.

With the Hi-Velocity System you want to maintain your house within a 5° temperature range. Residential heating/cooling systems are designed to maintain a set temperature within the home. A big misconception that people have is to turn off their air conditioning/heating when they leave the home, and “crank” it up/down when they return home, thinking that this is efficient. For a residential heating/cooling system to bring up or down the temperature drastically like this (for example let’s say more than 5°), the system will have to run much longer than it would have throughout the day, therefore consuming more power and making it much more inefficient.

## Operation Notes:

- With the variable speed control for heating, the amount of air delivered can be reduced, which will reduce the amount of heat delivered from the fan coil.
- In cooling mode, the fan coil will automatically switch to full high speed and bypass both constant and heating fan controls to supply maximum airflow.
- High RPM motors with sealed bearings require no oiling or maintenance.
- The Hi-Velocity System can be used with any 24 volt thermostat. On some of the newer thermostats there is a fan switch which can be set in the “Auto” or “On” position. It is recommended to have the switch set in the “auto” position. If the fan switch is in the “on” position it will override both dial controls so they cannot be adjusted.

# Hi-Velocity Tools

## Heat Load Calculator

As with any heating and cooling package, Hi-Velocity Systems require a detailed assessment of the structure, ambient outside temperatures and other factors that are critical to ensure that the system is properly sized for maximum efficiency. The ESP Heat Calculator is designed to provide fast and accurate load calculations to ease the design of Hi-Velocity Systems. The installing contractor has the ability to design the appropriate system and provide a layout. If the contractor wishes, he can have the wholesaler design the system, or send it to the factory for sizing.

NUMBER OF VENTS NEEDED FOR COOLING, DEPENDANT UPON CHILLED WATER TEMPERATURE

TOTAL TONS: \_\_\_\_\_

ROOM NAME: \_\_\_\_\_ Cooling Indoor Temp: 70°F Heating Water Temp: \_\_\_\_\_ Heating Only Cooling Only

Job Number: \_\_\_\_\_ Date: \_\_\_\_\_

Job Name: \_\_\_\_\_

Job Number: \_\_\_\_\_

Temp Diff (Heating): 35°F

Date: \_\_\_\_\_

Designed By: \_\_\_\_\_

Job Number: \_\_\_\_\_

Job Name: \_\_\_\_\_

Energy Saving Products Ltd.  
12615-124 Street  
Edmonton, AB, CA T5L 0N8  
Phone (780) 453-2093  
FAX (780) 453-1932  
www.hi-velocity.com

Item	Construction	Factor
Skylights	Double Glazed	0.78
Duct Sealer	Foil Duct Tape	1.00
Glass	Double Glazed	0.62
Cold Floor Area	R-12 Insulation (3-1/2")	0.08
Cold Floor Perimeter	Slab Edge Insulation	0.50
Exposed Ceiling	R-30 Insulation (9")	0.03
Standard Doors	1" Solid Core	0.67
Glass Doors	High Eff. Patio Door	0.92
Exposed Wall	R-20 Insulation (6")	0.04
Construction	Modern	1.32

Relative Humidity (Summer): 50%

Air Change / Hour: 0.3

Altitude above sea level (feet): 500

Barometric Pressure (" Hg): 29.92

Outdoor Heating Temp. (" F): -15

Outdoor Cooling Dry Bulb Temp. (" F): 95

Wind Speed (Mph): 12

Prevailing Wind Direction (Degrees): 270

Company  
Address 1  
Address 2  
Postal / Zip  
Phone  
Fax

HC 3.4

Heat Calc Version 3.4  
Load Calculation and Equipment Sizing for  
Hi-Velocity Systems by Energy Saving Products

## Quick Quote Calculator

The Quick Quote Program has been designed to allow for simplified quoting of the Hi-Velocity System. It enables the user to easily obtain pricing and product codes on the main Hi-Velocity components.

Quantity	Product Description	Product Code	Price	Total
	HV - 50 - BU	10013100050		
	RCM - 50	10011201050		
	HCA - 50	10010210050		
	AFD 2x10 R-4	10020120010		
	AFD 2x15 R-4	10020120015		
	UFD 2x25 R-4	10020120025		
	RA - 100	10021200100		
	FR - 50	10020200050		
	<b>Total</b>			

# Space Saver Hi-Velocity Fan Coil

When Every Square Foot Counts

Patented Adjustable  
Rough-In Boot, Quick  
and Easy to Install

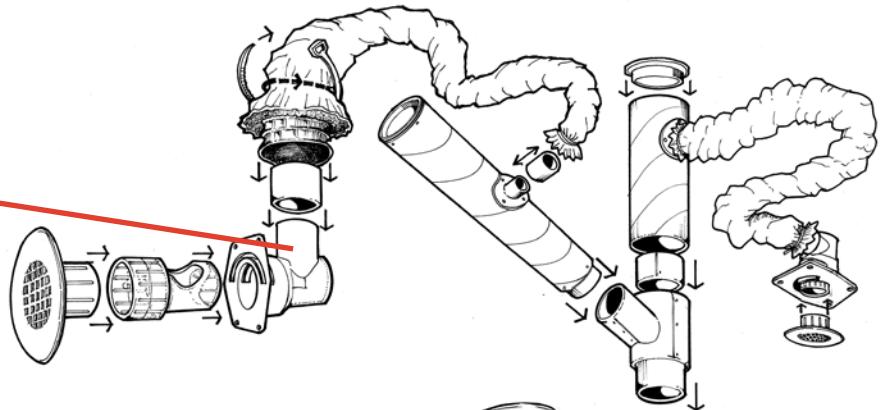

Flexible 2" Supply ducts

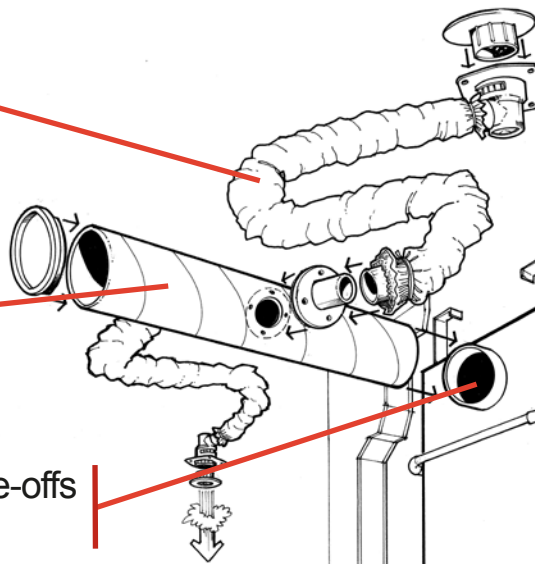

Round Supply Plenum

5 Possible Supply take-offs  
to choose from.

Hi-Velocity Space Saver  
Fan Coil, so compact it  
can fit in a closet

Usable with dual purpose  
hot water heater, boiler, and  
heat pump applications.

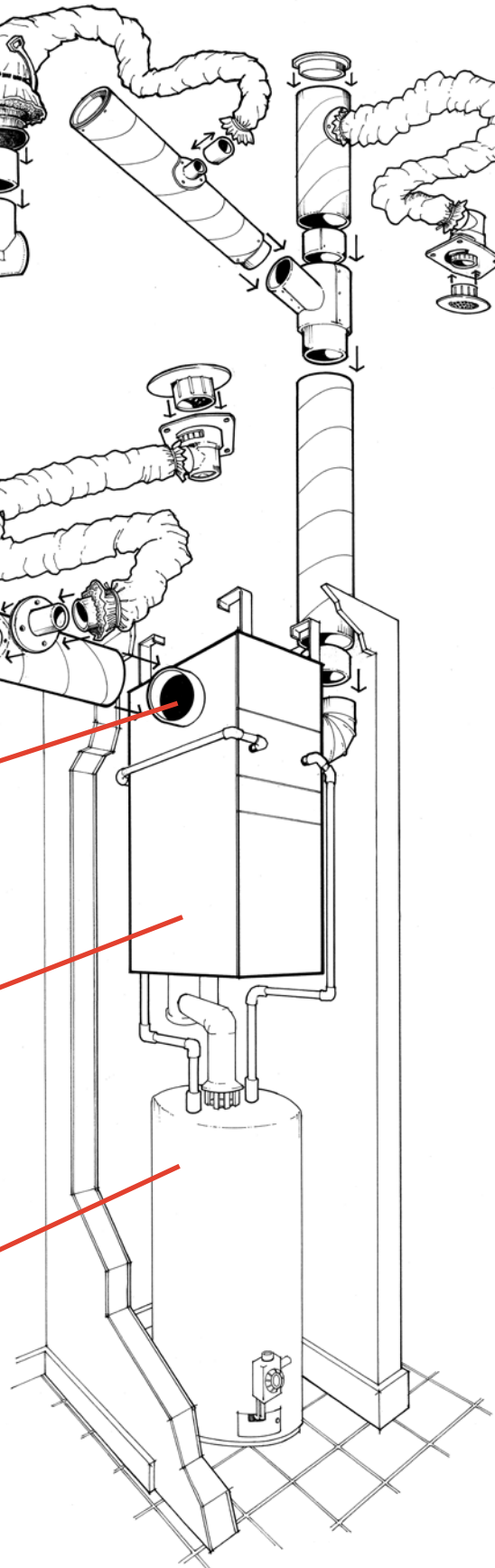

# Why Choose the Hi-Velocity System?

We at Energy Saving Products Ltd. work hard to continually improve upon ourselves and our products. We believe the products are a representation of our character, with the end user always in mind. Our team of professionals in the Small Duct High Velocity industry are always adapting and inventing new technologies to provide optimal solutions for our customers.

## Our Team

Energy Saving Products Ltd., established in 1983, manufactures the **Hi-Velocity Systems** product line for residential, commercial and multi-family markets. Our facilities house Administration, Sales, Design, Manufacturing, as well as Research & Development complete with an in-house test lab. Energy Saving Products prides itself on Customer Service and provides design services and contractor support.

***Comfort from floor to ceiling,  
Satisfaction from room to room,  
with***

***Hi-Velocity  
Systems***

***It's not just a dream, it's reality.***

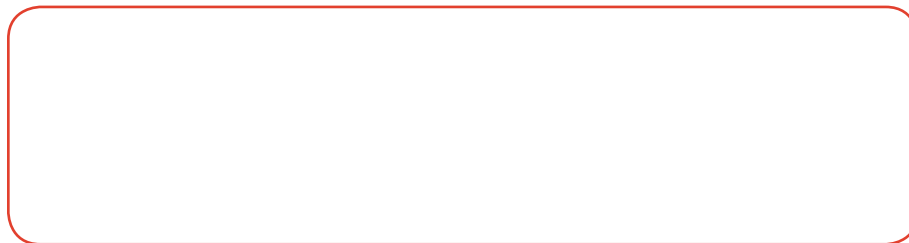

Phone: (780) 453-2093  
Fax: (780) 453-1932  
Toll Free: 1-888-652-2219

[www.hi-velocity.com](http://www.hi-velocity.com)